

## LED SN Series

- ✓ **Function integration, 3D penetrating fill light**
- ✓ **8 spectrum combinations, flexible and free.**
- ✓ **4 dimming control modes, easy to adjust.**
- ✓ **Create your own height and density.**

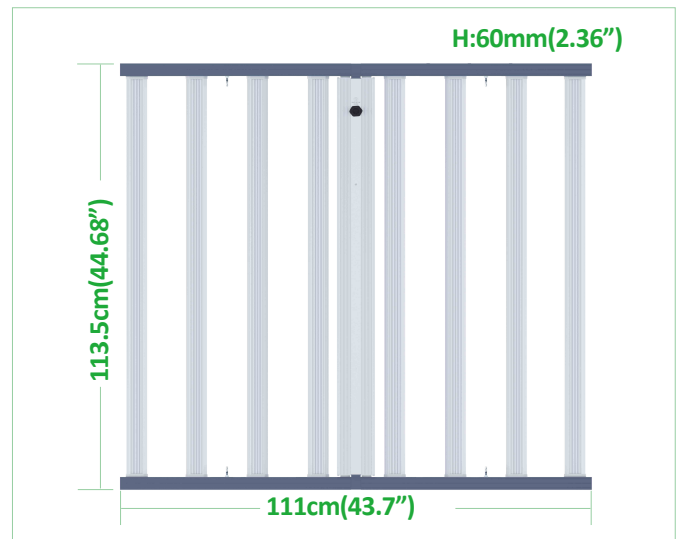

### Features

• **Function integration, 3D penetrating fill light:**

Nanolux Interlight LED makes your lighting solution three-dimensional and uniform, delivers supplemental light for plants from all directions and angles, boosts plant development efficiency and productivity, and allows you to reap the advantages of more plantings sooner.

• **8 spectrum combinations, flexible and free:**

The top full-spectrum/UV/IR, red and blue light between plants, the whole machine can achieve eight spectrum combination configurations. Flexible setup to better satisfy the supplemental light requirements of various crops and growth stages.

• **3 dimming control modes, easy to adjust:**

0-10V, RS485, manual control of UV & IR irradiation duration, multiple dimming methods to tailor the production environment for plants.

• **Create your own height and density :**

Based on the real conditions, Nanolux Interlight LED can simply modify the top and lower heights of 10-150cm and the left and right density of 100mm.

## Specifications

Product model	LED SN630 Pro	LED SN720 Pro	LED SN860 Pro	LED SN1000 Pro	LED SN1200 Pro
Product code	80.01.0411	80.01.0417	80.01.0394	80.01.0409	80.01.0408
Input power	630 W	720 W	860 W	1000 W	1200 W
Light Bars	6 bars	6 bars	8 bars	10 bars	10 bars
Dimming	0-10V, RS485				
Input voltage	AC 120V-277V				
Light output PPF	1830 $\mu\text{mol/s}$	2090 $\mu\text{mol/s}$	2500 $\mu\text{mol/s}$	2900 $\mu\text{mol/s}$	3480 $\mu\text{mol/s}$
Efficiency	2.90 $\mu\text{mol/J}$				
Input frequency	50/60Hz				
Light distribution	120°				
Mounting height	8" - 24" (20-60cm) above canopy				
Operating temperature	0°C~35°C				
Operating humidity	0~95%				
Power factor	$\geq 0.97$				
Total harmonic distortion	$\leq 15\%$				
Requirement of installment	Comply with ETL/CE/EAC/UKCA/FCC/DLC/ROHS certificate				
Lifetime L90	> 50,000hrs				
IP rating	IP65				
Product dimensions	1135x1110x60mm				
Product weight	8.7KG	10.2KG			12.5KG
Packing dimensions	1160x140x620mm				
Gross weight	11.8KG	13.3KG			15.0KG
Loading quantity	20GP: 288 Cartons 40HQ: 684 Cartons				

## AC Input\* (Case Example: 860W)

AC voltage	120V	208V	220V	240V	277V
AC current	7.40A	4.20A	3.90A	3.60A	3.10A
AC power	880W	865W	862W	860W	859W
Power factor	0.99	0.99	0.98	0.98	0.97

\* At 25°C (77°F) Ambient Temperature

## Spectrum Option

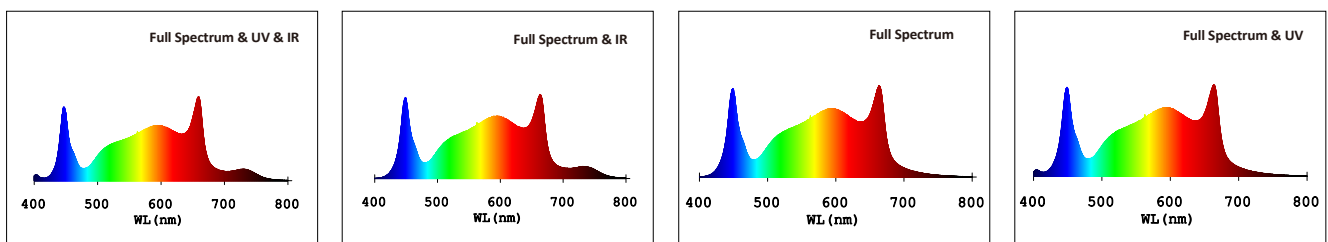

### Intracanopy LED Light (compatible with SN series)

Product model	Intracanopy LED Light
Product code	80.03.0486
Input power	20 W
Input voltage	DC 54V-58V
Light output PPF	60 $\mu\text{mol/s}$
Efficiency	3.0 $\mu\text{mol/J}$
Light distribution	360°
Mounting height	4"- 59" (10-150cm) above canopy
Operating temperature	0°C~35°C
Operating humidity	0~95%
Power factor	$\cong 0.97$
Total harmonic distortion	$\cong 15\%$
Requirement of installment	Comply with ETL/CE/EAC/UKCA/FCC/DLC/ROHS certificate
Lifetime L90	> 50,000hrs
IP rating	IP66
Product dimensions	1180x65x45mm(2PCS)
Product weight	1.1 KG
Packing dimensions	1195x210x205mm(24PCS)
Gross weight	14.7 KG
Loading Quantity	20GP: 524 Cartons 40HQ: 1320 Cartons

\* Optional 1-4 Interlight LEDs for matching use

### Spectrum Option

