



INDUSTRY NINE SOLiX SERVICE GUIDE

HUB SERVICE

Industry Nine products are designed to keep you in the saddle and out of the service queue. Regular service and maintenance is simple and can be performed with basic tools readily available to the home or shop mechanic - **no proprietary tools are required.**

To properly service your Industry Nine SOLiX series hubs, please follow the steps below.

For more information: Call 828-210-5113, email service@industry-nine.com or visit industry-nine.com/support

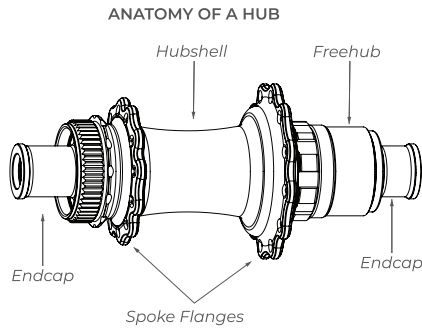

TOOLS
RUBBER / PLASTIC MALLET



BEARING LAYOUT CHART

HUBSHELL	DRIVE SIDE	NON-DRIVE SIDE
Center Lock Mountain Front	1 x 17287	1 x 17287
Center Lock Mountain Rear	1 x 61902	1 x 61902
Center Lock Dropbar Front	1 x 15267	1 x 15267
Center Lock Dropbar Rear	1 x 61902	1 x 61902
FREEHUB	INBOARD	OUTBOARD
SOLiX XD, XD-R, HG, HG-11	1 x 152610	1 x 15267
MS, MS-R, Campy N3W	1 x 31802_W	1 x 31802

PRO TIPS: If you are having trouble getting the endcaps off, a (non-marring) soft jawed vice or soft jawed pliers can be used for removal.*

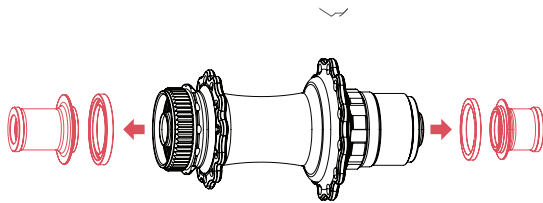

1.1 Rear Hub Disassembly

To disassemble your Solix hubs you need to first remove the **endcaps** from the axle. The endcaps are held in place with a rubber o-ring seated in the endcap. *Endcaps do not require tools for removal.** However, if more force is needed, protect the end cap with shop rag and pull off with an axle vice or soft jaw pliers. Once the endcaps are removed you will need to remove the **seals** housed in the hub and freehub. The **seals** can be removed with a pick.

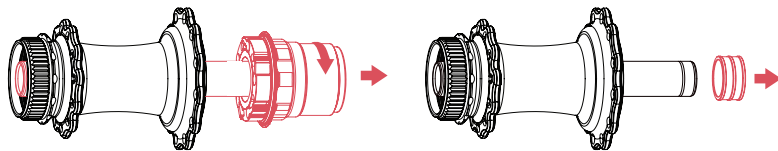

1.2 Freehub Removal

Once the endcaps and seals are removed, the **freehub** can be pulled off by hand. Hold the wheel with the freehub facing down, as it disengages from the driving. Rotate the wheel counterclockwise while gently pulling Outward. Remove the **ribbed spacer** from the axle and keep it with the freehub.

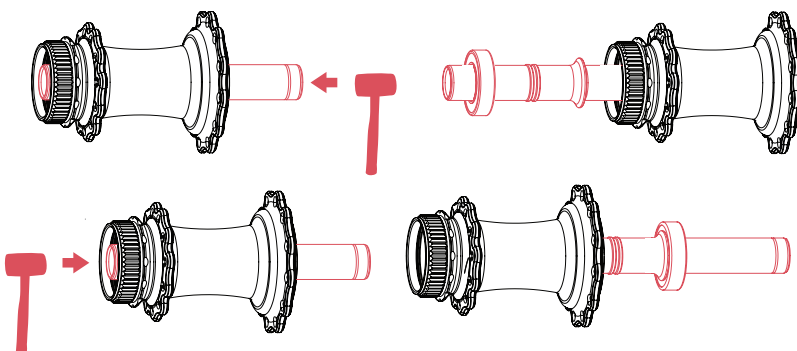

1.3 Rear Hub Axle + Bearing Removal

With both endcaps, seals and the freehub removed you will be left with an **axle** that is exposed on both sides. With a mallet, tap from the drive side to dislodge the bearing and axle from the non drive side.

The **axle** has shoulders that contact the inner race of the bearing, and will drive the bearing out of the hub shell. Reinsert the **axle** and use it to drive out the drive side bearing in the same manner you removed the first. The remaining bearing can also be removed with a blind bearing puller or carefully with a drift/punch and a mallet.



INDUSTRY NINE SOLiX SERVICE GUIDE

HUB SERVICE

PRO TIPS:

- *Reference Bearing Layout Chart for proper bearing size by hubshell type.
- Note grey side of bearing is designed to face outward from the product.
- To re-assemble, follow reverse order from disassembly. Take care to put all bearings in as straight as possible.
- You can install the bearings with a threaded rod bearing press, an arbor press, or a vice may be used to press in the bearings evenly and without impact.
- Be sure to thoroughly clean all components prior to assembly.

TOOLS BEARING PRESS



BEARING LAYOUT CHART

HUBSHELL	DRIVE SIDE	NON-DRIVE SIDE
Center Lock Mountain Front	1 x 17287	1 x 17287
Center Lock Mountain Rear	1 x 61902	1 x 61902
Center Lock Dropbar Front	1 x 15267	1 x 15267
Center Lock Dropbar Rear	1 x 61902	1 x 61902
FREEHUB	INBOARD	OUTBOARD
SOLiX XD, XD-R, HG, HG-11	1 x 152610	1 x 15267
MS, MS-R, Campy N3W	1 x 31802_W	1 x 31802

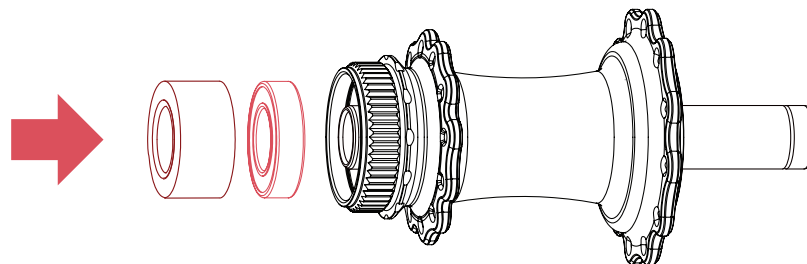
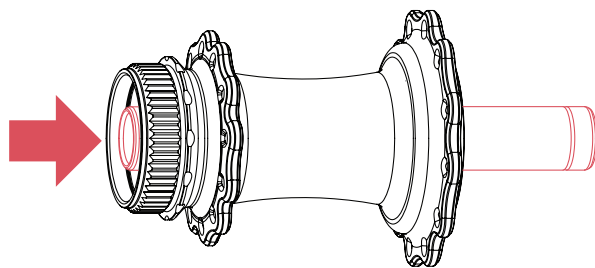
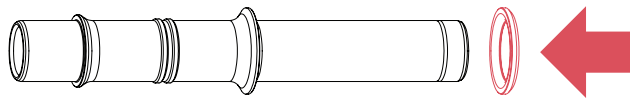
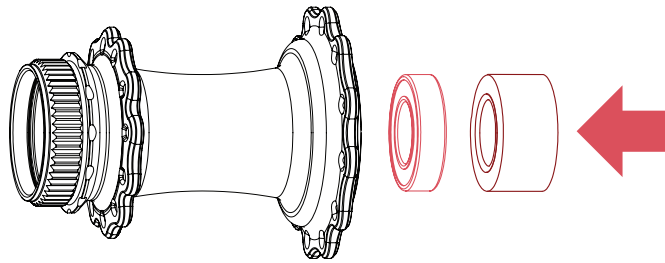

1.4 Rear Hub Assembly

Start by lining the inside of your clean bearing bores with a thin film of grease. Then press the **drive side bearing** into the drive side of the hub using a flat **bearing press**. After the drive side bearing has been pressed in, insert the hub's axle through from the non-drive side of the hub.

Make sure the **convex washer** is in place and oriented correctly on the axle shoulder.

Press the non-drive side bearing over the end of the axle, into the non-drive side of the hubshell with a flat bearing press. This will leave you with a hubshell that has an axle held captive by the two bearings.*



INDUSTRY NINE SOLIX SERVICE GUIDE

HUB SERVICE

PRO TIPS:

· Try to maintain perpendicularly to the bearing bore when removing bearings.

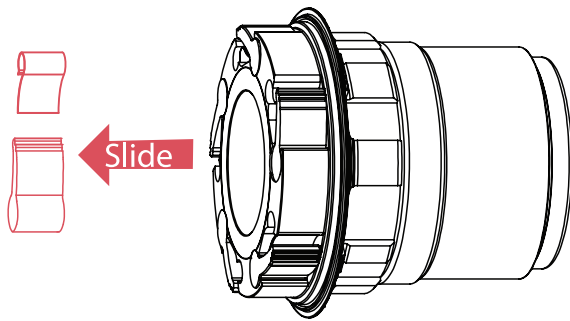

2.1 Freehub Disassembly + Service

Freehub body components are easily removed by hand. The **pawls and springs** slide out of the pawl and spring pockets.

2.2 Freehub Seal Access

This step is typically unnecessary in most service situations. Once the freehub is removed from the hub, you can then access and service the freehub seal if needed. The **freehub seal** can be lifted from its seat with gentle pressure. Use a 3mm flathead or pick to dislodge the freehub seal. You can replace the seal at this time if it is damaged. Install the seal with the sealing lip facing out and press firmly around the seal to ensure it is fully seated in its housing.

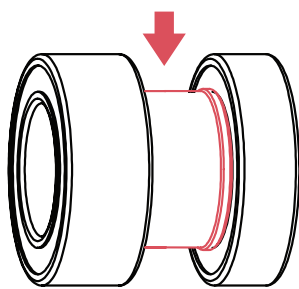
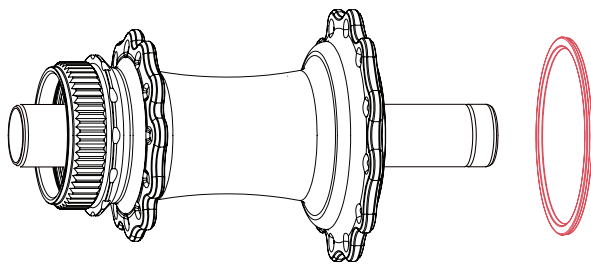

INTERNAL VIEW

2.3 Freehub Bearing Removal

PLEASE NOTE: Bearing removal sequence critical!

Once the drive components are removed from the freehub shell there will be 1 inboard and 1 outboard bearing with a **cylindrical spacer** between them. The cylindrical spacer can be shifted out of the way to access the inner race of the bearings. Careful removal of the outermost bearing with a blind bearing puller or tapping out with a drift or a punch will remove the bearing, allowing the spacer to be withdrawn.

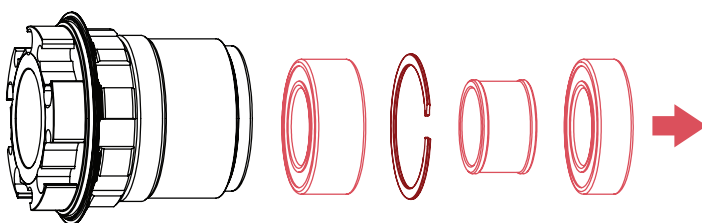

Using a 3mm flathead you can remove the **retaining ring** securing the remaining bearing. The remaining bearing should be removed to the outboard side of the freehub using the non drive side of the rear axle as a tool.

HUB SERVICE

PRO TIPS:

- *Reference Bearing Layout Chart for proper bearing size by hubshell type.
- Note grey side of bearing is designed to face outward from the product.
- To re-assemble, follow reverse order from disassembly. Take care to put all bearings in as straight as possible.
- You can install the bearings with a threaded rod bearing press, an arbor press, or a vice may be used to press the bearings in evenly and without impact.
- If there is additional drag found after assembly, it might be a result of an improper seal installation.
- Be sure to thoroughly clean all components prior to assembly.

TOOLS BEARING PRESS



BEARING LAYOUT CHART

HUBSHELL	DRIVE SIDE	NON-DRIVE SIDE
Center Lock Mountain Front	1 x 17287	1 x 17287
Center Lock Mountain Rear	1 x 61902	1 x 61902
Center Lock Dropbar Front	1 x 15267	1 x 15267
Center Lock Dropbar Rear	1 x 61902	1 x 61902

FREEHUB	INBOARD	OUTBOARD
SOLiX XD, XD-R, HG, HG-11	1 x 152610	1 x 15267
MS, MS-R, Campy N3W	1 x 31802_W	1 x 31802

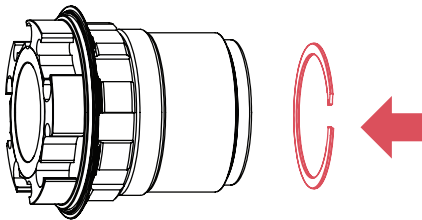
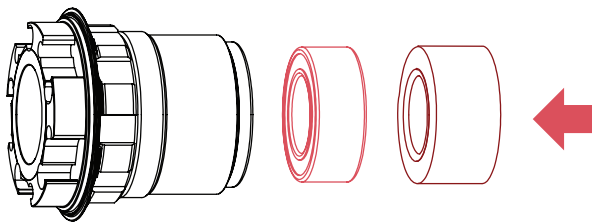

3.1 Inboard Freehub Bearing Assembly

Start by pressing the inboard double row bearing into the outboard side of the freehub using a bearing press. Reinstall the retaining ring and ensure it is snapped into position.

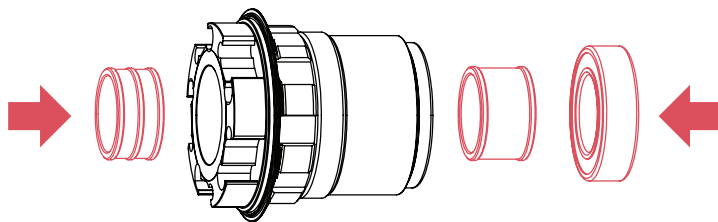

3.2 Outboard Freehub Bearing Assembly

Place the cylindrical spacer in between the two bearings. Press the outboard side bearing into the outboard side of the freehub while supporting the inner race of the inboard bearing with the ribbed spacer.

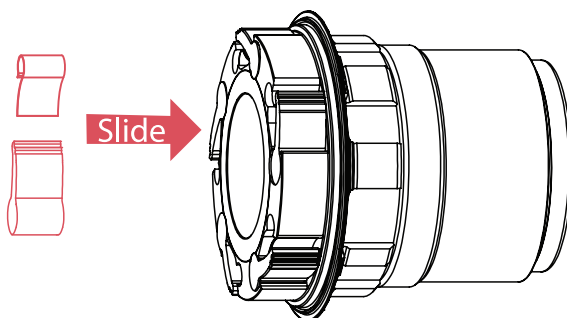

3.3 Spring and Pawl Assembly

The pawls and springs slide into the pawl and spring pockets. Insert spring first, depress spring with pick to insert pawl. Be aware the three teeth on the pawls face the driving.

INDUSTRY NINE SOLiX SERVICE GUIDE

HUB SERVICE

PRO TIPS:

- Apply grease to driving and pawls to quiet the freehub sound.
- Apply oil to driving and pawls to increase the freehub sound.

TOOLS

DUMONDE TECH FREEHUB GREASE + OIL



3.4 Free Hub Installation on Hub Shell

Slide the **ribbed spacer** onto the axle.

Apply a few drops of Dumonde Tech Freehub Oil to the driving, pawls, and freehub seal, as well as a thin film of grease to the axle.

Push the **freehub** onto the axle. Be sure that the freehub's **inner spacer is centered**, then slide the freehub over the axle onto the rear hub's drive side.

You will need to **center the cylindrical spacer** with your finger to in order for it to slide onto the axle.

Once the freehub makes contact with the driving gently press the **freehub** onto the hub while twisting it counter-clockwise to engage the pawls into the driving.

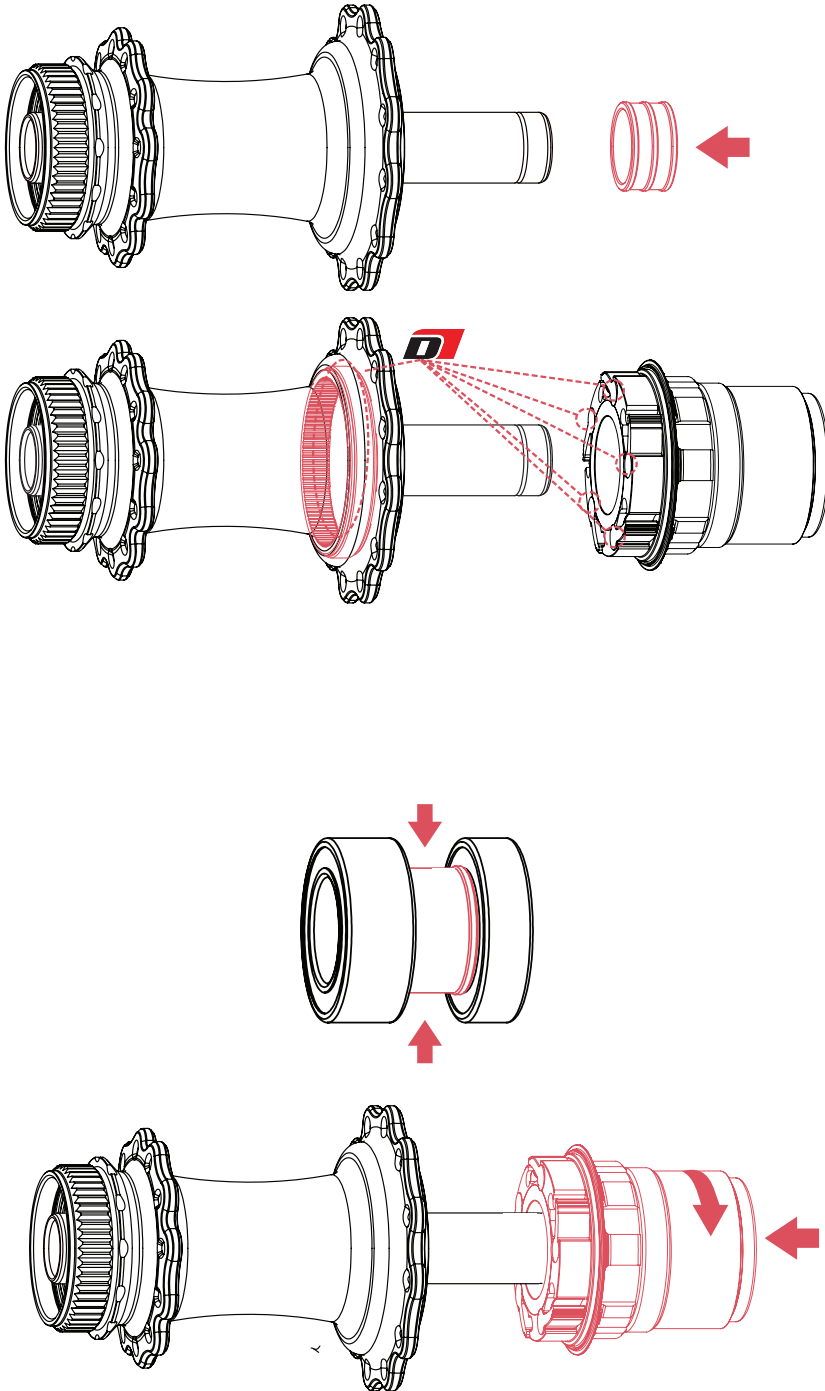

TOOLS
MARINE GREASE



4.1 Endcap Seals, Endcaps + Final Rear Hub Assembly

With the bearings, axle, and freehub installed you can now install the endcap seals into the hub and freehub. Put a film of marine grade (preferably) or other **waterproof grease** onto the front face of the bearing seal before installing.

Install the seals with the lip facing out and apply a film of grease to the seal faces. Use a bearing press or pick to ensure the seals are fully seated against the bearings. Once the seals are installed you can press the endcaps onto the axle to complete your rear hub assembly.

When pushing the endcap on grease may seep out of the edges. Wipe any excess grease. The marine grease creates a membrane that will help keep your bearings from contamination that could reduce bearing life.

5.1 Front Hub Disassembly

The front hub consists of a cylindrical axle spacer held in place by two bearings and two **endcaps** pressed onto each side.

The front hub's endcaps are held in place with an o-ring seated in the endcap. The endcaps can be removed with a light tug. If more force is needed, protect the end cap with an axle vice or shop rag and pull off with a vice or pliers.

Be careful not to damage the face that makes contact with your fork! Once the endcaps are removed you will need to remove the **seals** housed in the hub. The seals can be removed with a pick.

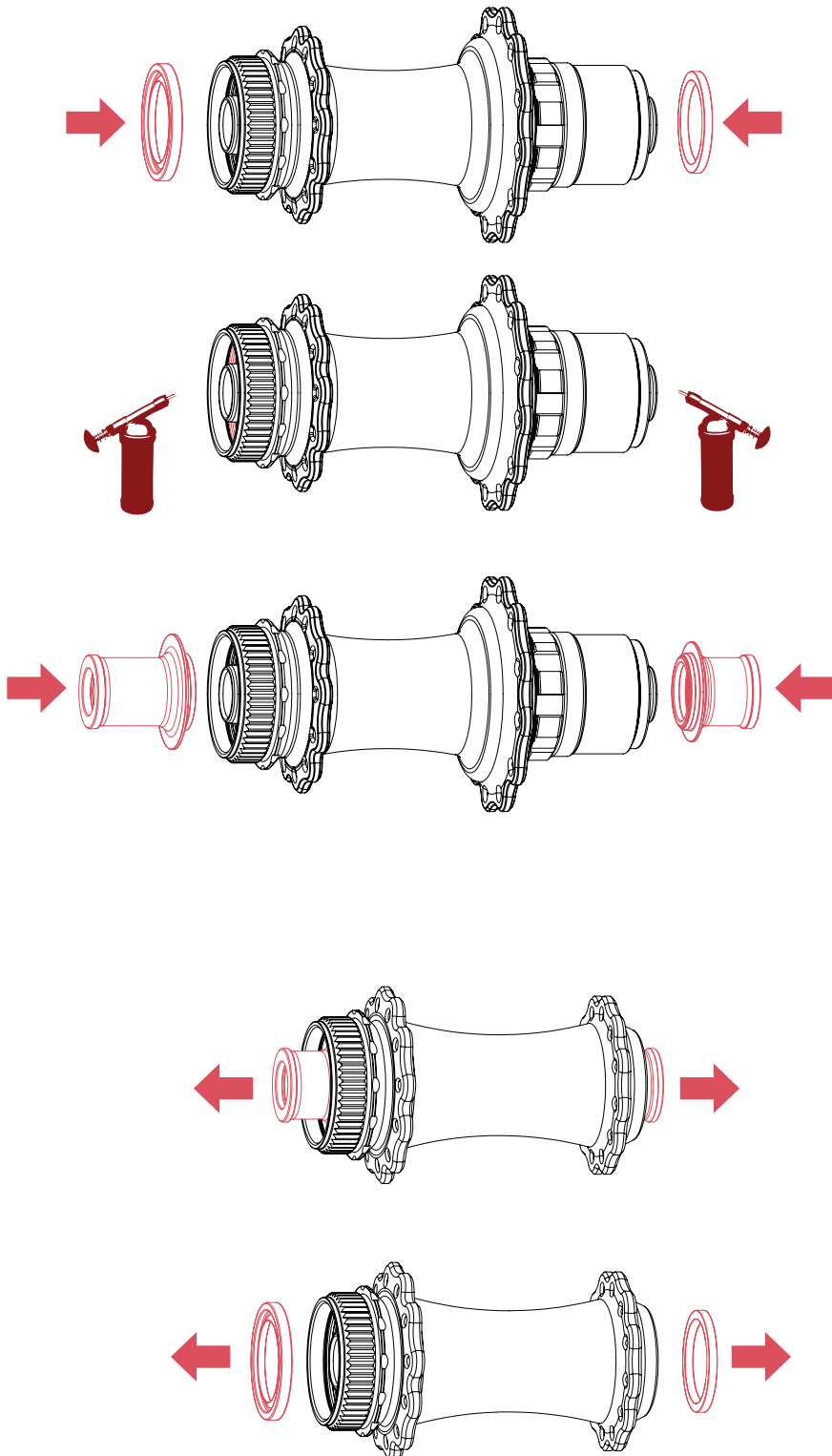

INDUSTRY NINE SOLiX SERVICE GUIDE

HUB SERVICE

PRO TIPS:

- *Reference Bearing Layout Chart for proper bearing size by hubshell type.
- Note grey side of bearing is designed to face outward from the product.
- To re-assemble, follow reverse order from disassembly. Take care to put all bearings in as straight as possible.
- You can install the bearings with a threaded rod bearing press, an arbor press, or a vice may be used to press the bearings in evenly and without impact.

TOOLS BEARING PRESS



BEARING LAYOUT CHART

HUSHELL	DRIVE SIDE	NON-DRIVE SIDE
Center Lock Mountain Front	1 x 17287	1 x 17287
Center Lock Mountain Rear	1 x 61902	1 x 61902
Center Lock Dropbar Front	1 x 15267	1 x 15267
Center Lock Dropbar Rear	1 x 61902	1 x 61902
FREEHUB	INBOARD	OUTBOARD
SOLiX XD, XD-R, HG, HG-11	1 x 152610	1 x 15267
MS, MS-R, Campy N3W	1 x 31802_W	1 x 31802

5.2 Front Hub Bearing Removal

With both endcaps and seals removed you can now remove the bearings.

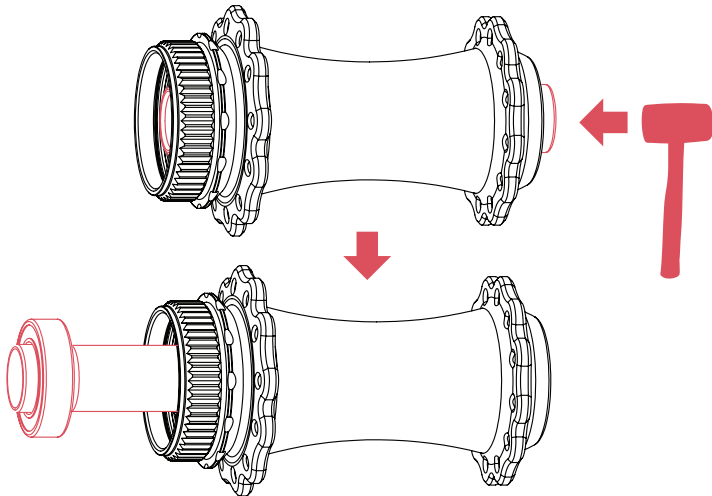

These can be removed by placing the endcap removal rod in the drive side **axle** and using a mallet to dislodge the non drive side bearing. The **axle** has shoulders that contact the inner race of the bearing, and will drive the bearing out of the hub shell.

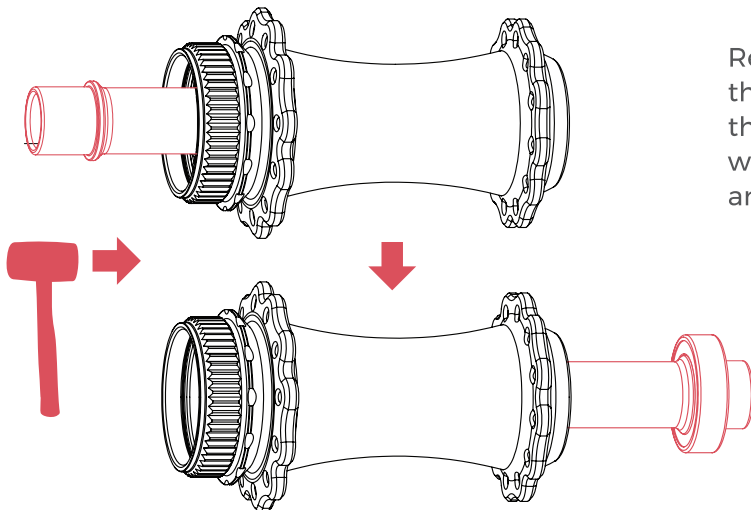

Reinsert the axle and end cap rod and use it to drive out the **drive side bearing** in the same manner you removed the first. The remaining bearing can also be removed with a blind bearing puller or carefully with a drift/punch and a mallet.



INDUSTRY NINE SOLiX SERVICE GUIDE

HUB SERVICE

PRO TIPS:

- *Reference Bearing Layout Chart for proper bearing size by hubshell type.
- Note grey side of bearing is designed to face outward from the product.
- To re-assemble, follow reverse order from disassembly. Take care to put all bearings in as straight as possible.
- You can install the bearings with a threaded rod bearing press, an arbor press, or a vice may be used to press the bearings in evenly and without impact.

TOOLS

BEARING PRESS
MARINE GREASE



BEARING LAYOUT CHART

HUBSHELL	DRIVE SIDE	NON-DRIVE SIDE
Center Lock Mountain Front	1 x 17287	1 x 17287
Center Lock Mountain Rear	1 x 61902	1 x 61902
Center Lock Dropbar Front	1 x 15267	1 x 15267
Center Lock Dropbar Rear	1 x 61902	1 x 61902
FREEHUB	INBOARD	OUTBOARD
SOLiX XD, XD-R, HG, HG-11	1 x 152610	1 x 15267
MS, MS-R, Campy N3W	1 x 31802_W	1 x 31802

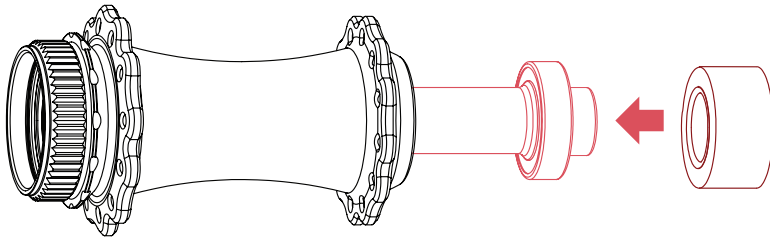
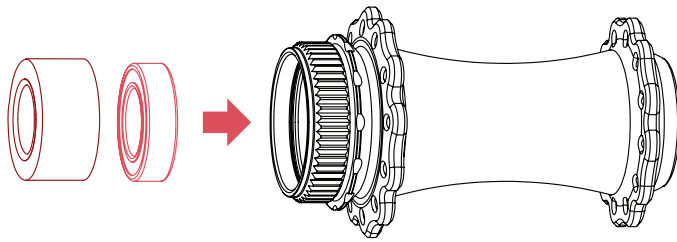
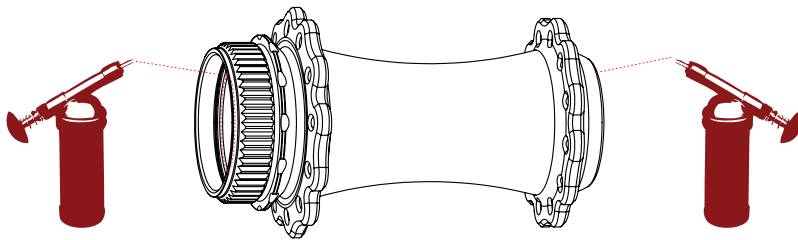

6.1 Front Hub Assembly

Start by lining the inside of your clean bearing bores with a thin film of **grease**, then press the **non-drive side bearing** into the non-drive side of the hub using a bearing press.

After the non-drive side bearing has been pressed in, insert the **hub's axle** through from the drive side of the hub.

Press the **drive side bearing** over the end of the axle, into the drive side of the hub shell.

This will leave you with a hub shell that has an axle held captive by the two bearings.*

INDUSTRY NINE SOLiX SERVICE GUIDE

HUB SERVICE

PRO TIPS:

- *Reference Bearing Layout Chart for proper bearing size by hubshell type.
- Note grey side of bearing is designed to face outward from the product.
- To re-assemble, follow reverse order from disassembly. Take care to put all bearings in as straight as possible.
- You can install the bearings with a threaded rod bearing press, an arbor press, or a vice may be used to press the bearings in evenly and without impact.

TOOLS

BEARING PRESS
MARINE GREASE

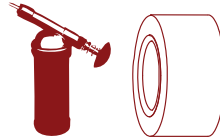

BEARING LAYOUT CHART

HUBSHELL	DRIVE SIDE	NON-DRIVE SIDE
Center Lock Mountain Front	1 x 17287	1 x 17287
Center Lock Mountain Rear	1 x 61902	1 x 61902
Center Lock Dropbar Front	1 x 15267	1 x 15267
Center Lock Dropbar Rear	1 x 61902	1 x 61902
FREEHUB	INBOARD	OUTBOARD
SOLiX XD, XD-R, HG, HG-11	1 x 152610	1 x 15267
MS, MS-R, Campy N3W	1 x 31802_W	1 x 31802

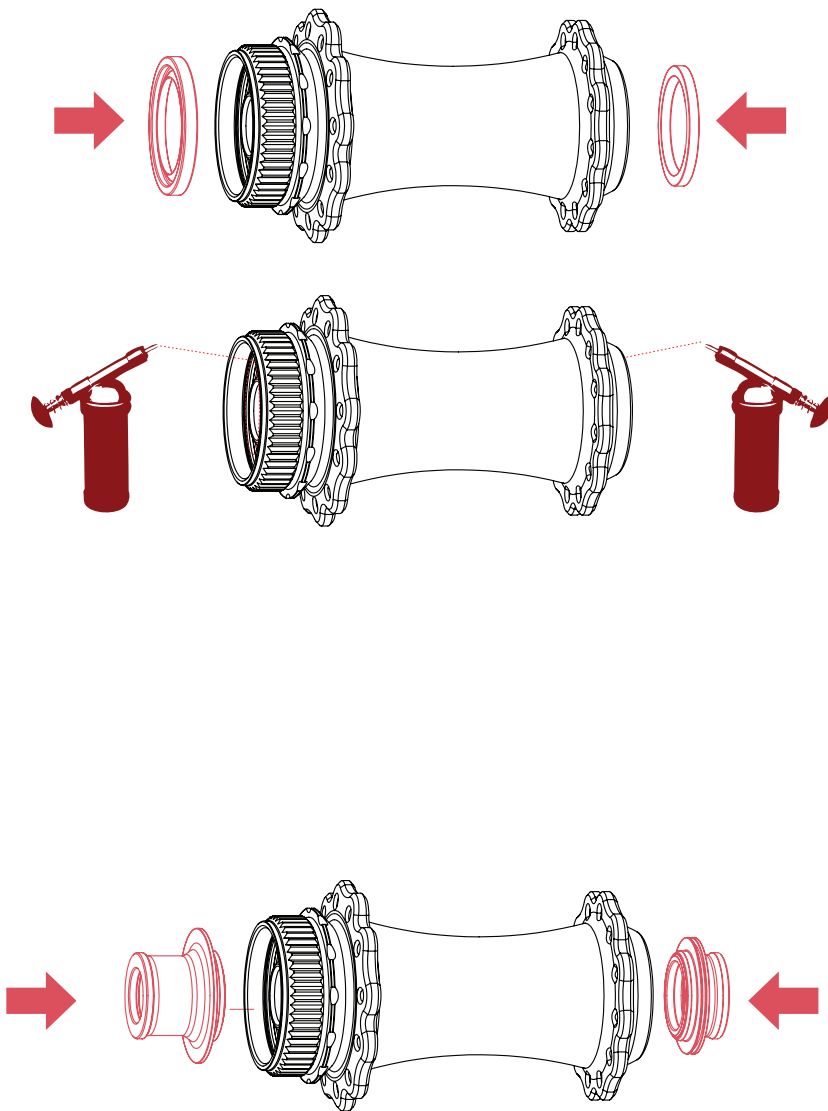

6.2 Front Endcap Installation

With the bearings and axle installed you can now install the **endcap seals** into the hub.

Put a film of marine grade (preferably) or other waterproof **grease** onto the front face of the bearing seal before installing.

Install the seals with the lip facing out and apply a film of grease to the seal faces. Use a bearing press or pick to ensure the seals are fully seated against the bearings. .

Once the seals are installed you can press the **endcaps** onto the axle to complete your front hub assembly. When pushing the endcap on grease may seep out of the edges. Wipe any excess grease

Marine grease creates a membrane that will help keep your bearings free from contamination that could reduce bearing life.